

## 5000 Series Large Area Scan Camera

### AX5F57MG250E

#### Product Features

- Gigabit Ethernet interface, with a maximum transmission distance of 100m;
- A patented flatness mediation scheme to eliminate area defocusing;
- Excellent heat dissipation design, precise temperature control and constant temperature maintenance;
- 512MB on-board cache for data transmission or image resend;
- Support Software Trigger/Hardware Trigger/Free Run Mode;
- Support user-defined ROI, horizontal mirroring and vertical mirroring;
- Support ISP functions including Auto Exposure/Auto Gain/Auto BlackLevel/Gamma Correction and LUT; Mono cameras support contrast;
- Support for FFC function to provide more uniform picture quality;
- Support fan speed adaptive function for setting the target temperature of the sensor;
- Conform to GigE Vision V2.0 protocol and GenICam standard;
- Support DC 24V voltage power supply;
- Conform to CE, FCC, KC, RoHS;



#### Dimensions (mm)

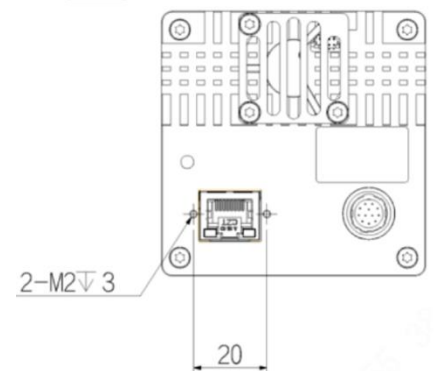
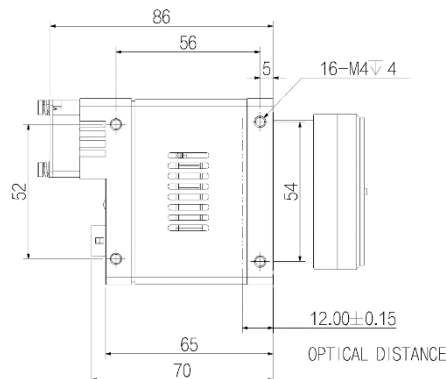
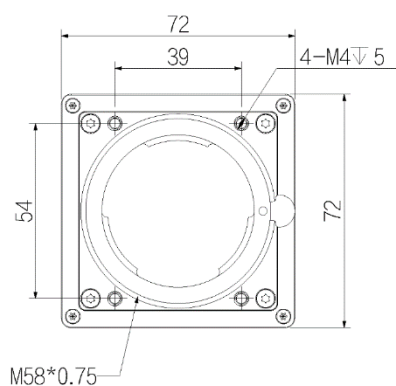

## Technical Specifications

Model Name	AX5F57MG250E
Sensor	GMAX3265
Sensor Type	29.9mm x 22.4mm CMOS
Shutter	Global
Resolution	9344 x 7000
Frame Rate	1.7
Bit Depth	12
Mono/Color	Mono
Pixel Size	3.2 x 3.2
Pixel	65MP
S/N Ratio	40dB
WDR	66dB
Image Format	Mono8/10/10Packed/12/12Packed
Binning	Support 1x2 2x1 2x2
ROI	Support
X-axis Flip	Support
Y-axis Flip	Support
Gain	1~32
Gamma	From 0 ~ 4, support LUT
Exposure Time	16μs~15S
Sync Mode	Software Trigger/Hardware Trigger/Free Run Mode
SPC	Support
User Setting	Support two sets of user-defined configurations
Storage	512MB data storage
Port	GigE
GPIO	3x Opto-isolated input, 3x Opto-isolated output, 1 RS232 serial port
Lens Mount	M58 x 0.75
Power Supply	DC 24V power supply via the 12-pin Hirose interface
Power Consumption	24V≈8.4W
Product Dimensions	76mm*76mm*65mm (not including the rear case connector)
Weight	482g
Working Environment	Storage: - 30°C~+80°C; Operation: - 30°C~+50°C

© 2021 IRAYPLE. All rights reserved. Design and specifications are subject to change without notice.

Pictures in the document are for reference only, and the actual product shall prevail.